

SSU 2000/SSU 2000e

Synchronization Supply Unit (SSU) for Carrier-Grade Networks



SSU 2000



SSU 2000e

Key Features

- High capacity, modular system
- Integrated GNSS (GPS and GLONASS)
- E1, T1, CC, RS-422 outputs
- NTP server with hardware time stamping
- IEEE 1588 (PTP) Grandmaster
- SyncE option on PTP ports
- RADIUS option
- Performance monitoring on all inputs
- Management: SNMP, ICS, TL1
- TimePictra Synchronization Management System support

Key Benefits

- Single platform for TDM, NTP, PTP and SyncE
- Fully redundant for service delivery protection
- High capacity: E1 and T1 ports, NTP transactions, PTP clients
- Proven interoperability

Major Applications

- Primary Reference Source (PRS), PRC based on Global Navigational Satellite System (GNSS)
- SSU, Building Integrated Timing Supply (BITS), Stand Alone Synchronization Equipment (SASE), Timing Signal Generator (TSG)
- SDH/SONET, Ethernet, GPON networks
- 2G/3G and 4G/LTE networks
- Telecommunications, power utility, government and other private networks

The Symmetricom® SSU 2000 and SSU 2000e are fully manageable synchronization systems used by communications network operators to generate and distribute superior synchronization signals for their networks. The SSU 2000 conforms to ANSI standards and is NEBS certified, while the SSU 2000e is ETSI certified. Both systems use the same plug-in cards.

In addition to traditional frequency network timing capabilities for SDH/SONET networks, the SSU 2000/SSU 2000e supports packet network synchronization with carrier-grade Network Time Protocol (NTP) server and IEEE 1588 Precision Time Protocol (PTP) Grandmaster capabilities. The platform supports the seamless introduction of SyncE output capabilities elements into your network through the optical Ethernet port on the PTP grandmaster card. The SSU 2000 and SSU 2000e use the latest hardware and software integration technologies to provide a complete synchronization system for current and future network needs.

The SSU 2000/SSU 2000e is a key element in the Symmetricom synchronization distribution architecture (SDA) for LTE networks, synchronizing frequency for backhaul networks with SyncE, supplying PTP sync for the 4G/LTE mobile stations, and providing NTP sync for residential small cells.

High Capacity, High Availability Architecture

The SSU 2000/SSU 2000e architecture is designed to integrate intelligent, functional cards into a flexible, fully redundant system to satisfy current capacity and synchronization technology requirements and allow incremental capacity growth and deployment of new capabilities with additional plug-in cards as they are needed.

The SDU 2000/SDU 2000e Synchronization Distribution Unit (SDU) expansion shelves connect to a corresponding SSU 2000/SSU 2000e main shelf to provide additional output signals. The expansion shelves use the framing and synchronization features of the main shelf to drive an array of output cards. Any combination of T1, E1/2048 kHz, Composite Clock and RS-422 output cards, as well as NTP and PTP server cards may be installed.

T1 and E1 output cards may be configured in redundant pairs providing 20 1+1 fully protected outputs per pair. A fully configured SSU 2000 system provides T1/E1 output total capacity of up to 1280 unprotected ports or 640 protected ports. A fully configured SSU 2000e system supports up to 460 protected or unprotected ports.

Both shelf systems support high capacity NTP and PTP cards in single server or 1:1 protected configurations. Additional server

SSU 2000/SSU 2000e

cards grow total system client capacity. SyncE is available as an option on the PTP cards.

Frequency input signals are passed through in case of multiple internal failures, including clock failures. The shelves accept dual DC power and provide independent power conversion on each card. All cards are individually fused to protect the system in case of a short circuit on any one card.

Industry Standards Compliance, NEBS Level 3 Certification

The SSU 2000 and SSU 2000e are designed to meet the latest and evolving industry standards, including ANSI, Telcordia, ITU-T, ETSI, IEEE 1588 and CE/AS. The SSU 2000 is fully Network Equipment Building System (NEBS) Level 3 certified.

Intelligent Cards

Each card has an integrated CPU with software for superior reliability, flexibility and functionality. Cards can be hot-swapped while the unit is operating without any degradation of the output signals. Each intelligent card supports the management of critical, major and minor alarms. Powerful management can be performed to and within each card through the communication card, including in-service upgrades of software and programmable logic devices.

Auto-reconfiguration: If a card is removed and a like card installed in the same slot, the new card will be automatically configured to the same settings as the previous card.

GNSS Cards

The SSU 2000/SSU 2000e integrates single or dual satellite system receiver cards to meet primary reference clock requirements. Integrated capability delivers these key benefits:

- Flattens the number of levels in the synchronization distribution hierarchy

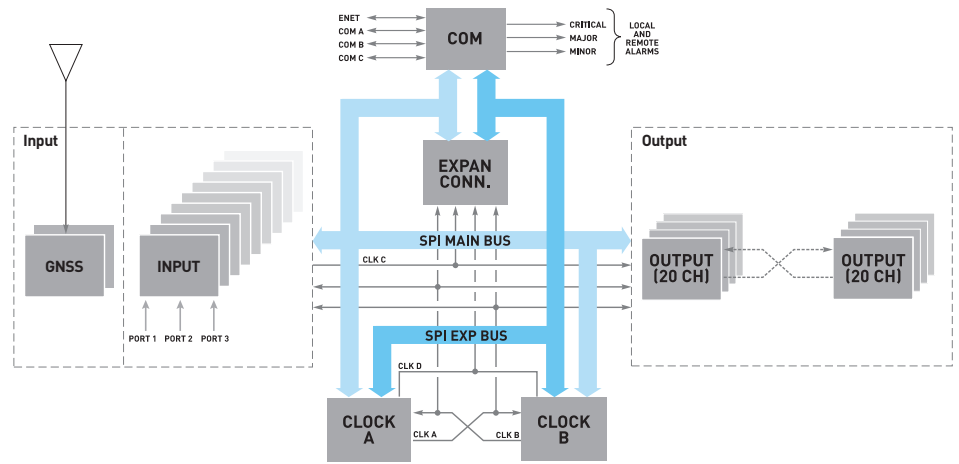

SSU 2000/SSU 2000e Block Diagram

- Improves the overall performance of the network
- Lowers the overall OAM&P costs (Operation, Administration, Maintenance, and Provisioning).
- Single unit PRS
- UTC traceable time source for integrated PTP grandmaster clocks and NTP servers

Two cards are available: The GNSS card supports GPS and GLONASS signals and can be locked to either one or both simultaneously. Also available is a dedicated GPS-only card.

Input Cards

The SSU 2000 accepts up to nine input cards; the SSU 2000e accepts up to three input cards. The platform supports the following input signals:

- T1 (framed)
- E1 (framed)
- SSM quality
- JSW and JCC (Japan)
- 1 MHz (sine or square)
- 1.544 MHz (sine or square)
- 2.048 MHz (sine or square)
- 5 MHz (sine or square)

- 10 MHz (sine or square)
- In the SSU 2000e each input slot supports connections for termination, bridging, monitoring and traffic pass-thru. These connectors provide performance monitoring, impedance termination and traffic pass through to network elements and input references.

Various input impedance panels are available for the SSU 2000 to support the following balanced or unbalanced signal impedances:

- 50 ohms (sine)
- 75 ohms (T1/E1)
- 100 ohms (T1)
- 120 ohms (E1)
- 133 ohms (CC)
- High impedance for timing extraction only (bridging mode)
- Panel/adaptor connection interfaces:
 - Wire wrap
 - BNC
 - Siemens
 - DE-9

Input signals are passed through to corresponding outputs in case of multiple internal failures, including clock failures.

SSU 2000/SSU 2000e

Intelligent Clock Cards, Superior Holdover Performance

The SSU 2000/SSU 2000e accepts single or dual clocks. Three clock cards are available to meet different international standards and specific holdover requirements: ITU-T Type 1 (ETSI Slave Clock, enhanced quartz oscillator), Type II (Stratum 2E, enhanced rubidium oscillator), and Type III (Stratum 3E, enhanced quartz oscillator). Redundant configurations may use a mix of technologies. In case of loss of GNSS and input references, the SSU 2000/SSU 2000e uses intelligent software to provide enhanced output performance beyond the required holdover stability. Its superior holdover capability retains stratum G.812 performance for three weeks during holdover conditions with Symmetricom rubidium technology.

Output Cards

The SSU 2000's main shelf supports 8 output cards, providing up to 160 unprotected outputs. Up to four expansion shelves can be added, providing up to 1120 additional unprotected output ports. The output cards may be configured for redundant operation.

The SSU 2000e's main shelf supports up to 6 output cards, providing up to 60 protected or unprotected output ports. Up to four expansion shelves can be added, providing up to 400 additional protected or unprotected output ports.

Any output card can be removed or inserted while power is applied without affecting the operation of any other card or the system. Various output cards are available to meet specific signal and interconnection requirements including T1, E1, CC, JSW, JCC, RS-422, NTP, and IEEE 1588 PTP. The activation of the output ports are fully user controllable.

E1/2.048 MHz Output Card

The E1/2.048 MHz output card has 20 ports that are software-selectable for either E1 or 2.048 MHz output signals. The E1 signal has a multiframe format, with selectable Channel Associated Signaling (CAS) or Common Channel Signaling (CCS).

T1 (DS1) Output Cards and Capabilities

The T1 output card has 20 ports. The T1 output card generates phase-locked output signals of 1.544 MHz.

E1 and T1 Line Retiming Units (LRU)

The SSU 2000 supports both E1 and T1 line retiming units (LRU). The LRU is comprised of a Line Re-timing Module (LRM) and a Cut-Through Assembly (CTA). The LRU is a four-port (quad) card. The LRU inserts E1 or T1 signals on both sides of a cross connect panel in a central office. Side 1 of the re-timer provides "3R" (Re-shape,

Re-amplify, and Re-time) for the signal to a client network element. When the LRU receives a data stream, it re-times the data with the transmit clock signal. The clock signal is inserted into the line route between two path-terminating elements. Side 1 is the direction in which timing is applied, and contains the line performance reporting and AIS generator. Side 2 provides "2R", which Re-shapes and Re-amplifies (regenerates) the signal from the client network element.

Composite Clock Output Card

The Composite Clock output card generates 20 signal pairs (TIP and RING signal pairs). Each output is a transformer-coupled symmetrical pair. Each output pair can be turned off independently of other channels. Relays on each output allow for disconnecting the driver output from the output pins.

NTP Performance	Enterprise Class	SSU 2000
Time Stamping Precision	Software (10µs)	Hardware (10ns)
Scalability	Fixed	Card based
Holdover	√	√
Redundancy		√
TL1 Management		√
NEBS		√

SSU 2000/SSU 2000e carrier-grade NTP meets high QoS requirements for NGN telecommunications network.

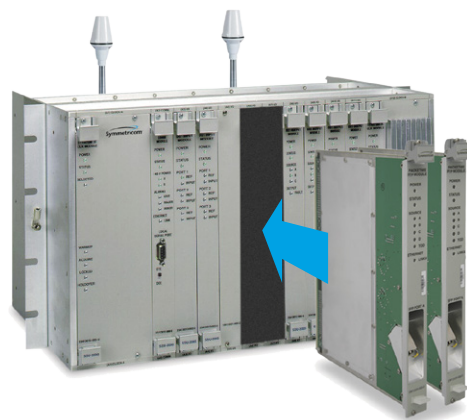

Symmetricom's NTP and PTP cards can be installed as single servers or redundant pairs in any available master or expansion shelf output slots.

SSU 2000/SSU 2000e

RS-422 Output Card

The RS-422 output card generates 10 balanced square-wave outputs (TIP and RING signal pairs on ports 1-10) and 10 single-ended (RING) TTL square wave outputs on ports 11-20. Each output can be turned off independently of other ports. Relays on each output disconnect the driver output from the output pins.

Connectivity

For the SSU 2000, there are a variety of input and output panels available with several types of connectors. These include DE9, wire-wrap, BNC, and Siemens type connectors. Also available are high density wire wrap panels in both 80 and 100 output versions. For the SSU2000e, DE9 connectors are included in the shelf design.

Synchronization Status Messages (SSM)

The input card reads and processes SSM in accordance with ITU-T and ANSI standards to determine the traceability of inputs. This traceability information is then used by the clock cards in selecting a reference signal,

and is embedded into the system's outputs. An embedded, editable table allows upgrades as standards evolve.

NTP Server Card

NTP requirements in telecommunication networks have rapidly evolved from a "best effort" utility to mission critical. With high performance NTP server cards the SSU 2000/SSU 2000e platform delivers carrier-grade NTP to meet demanding next generation network requirements. The NTP server cards provide the performance, scale, availability and security that assure high QoS delivery of advanced services such as IPTV, multimedia content delivery and residential small cells, as well as distributed BSS/OSS operations.

The NTP server cards are fully integrated into the SSU 2000/SSU 2000e platform. NTP cards can be installed as single servers or redundant pairs in any available master or expansion shelf output slot. NTP capacity scales up at a rate of up to 1000 fully authenticated transactions per second (TPS) or up to 1500 unauthenticated TPS for

each added card. Front-access NTP traffic ports utilize Small Form-factor Pluggable (SFP) modules for flexibility to support 100/1000BaseT electrical or 1000Base-X optical interfaces. NTP server cards can support both independent public and private network domains, providing added security and flexibility. All configuration and management is consolidated through SSU 2000 system management ports to maintain security and isolation from NTP traffic ports.

NTP cards for SSU 2000/SSU 2000e provide superior stability and protection through direct connection to the system backplane. NTP Stratum level 1 UTC (Universal Coordinated Time) traceability is established through the GNSS or GPS input card. NTP Cards for SSU 2000 can also operate at NTP Stratum level 2 with UTC time traceability back to a NTP Stratum 1 card located in another office.

PTP Grandmaster Card

With high-performance PTP Grandmaster server cards the SSU 2000/SSU 2000e

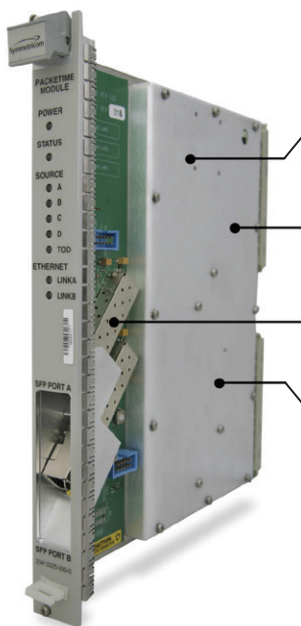

- Hardware time stamping delivers superior accuracy for telecom applications.
- High capacity NTP server engine supports up to 1500 transactions per second. System capacity scales up with additional cards.
- Dual front-access NTP traffic ports allow for flexible network configuration and protection.
- NTP Stratum 1 performance with direct time-of-day reference from GPS input of the SSU.



- Hardware time stamping delivers superior accuracy for telecom applications.
- System capacity scales up with additional cards.
- Traffic port allows for flexible network configuration and protection.

NTP Cards for the SSU 2000/SSU 2000e

PTP Cards for the SSU 2000/SSU 2000e. Optional SyncE capability.

SSU 2000/SSU 2000e

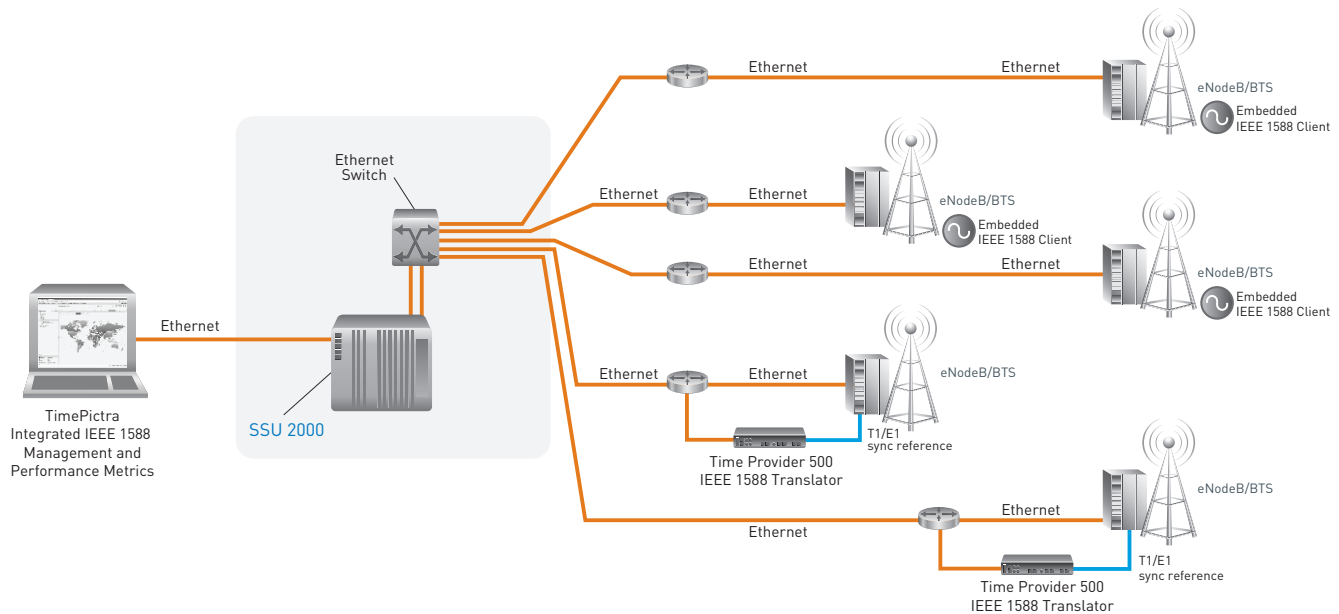

IEEE 1588 (PTP) Grandmaster Server Cards provide synchronization traceability over Ethernet to PTP client clocks in remote base stations.

platform delivers carrier-grade PTP to meet demanding NGN packet timing requirements. PTP cards provide the performance, scale, availability and security to deliver carrier-grade synchronization to remote PTP clients over Ethernet networks.

The Symmetricom PTP cards are fully integrated into the SSU 2000/SSU 2000e system. They can be installed as single servers or redundant pairs in any available master or expansion shelf output slot. PTP capacity scales up to 400 full-rate clients per card. Front-access PTP traffic ports utilize Small Form-factor Pluggable (SFP) modules for flexibility to support 100/1000Base-T electrical or 1000Base-X optical interfaces. All configuration and management is consolidated through SSU 2000/SSU 2000e system management ports to maintain security and isolation from PTP ports.

The PTP cards provide superior stability and protection through direct connection to the SSU 2000/SSU 2000e system

backplane. PTP cards operate either in arbitrary (ARB) timescale mode or in International Atomic Time (TAI) timescale with full UTC traceability through the SSU 2000/SSU 2000e integrated GNSS or GPS input card.

Synchronous Ethernet

The IEEE 1588 PTP card offers an option for SyncE physical layer frequency synchronization through the 1000Base-X optical Ethernet output port. Ethernet Synchronization Message Channel (ESMC) per the OSSP protocol is supported. Fully standards compliant SyncE with PTP makes the SSU 2000/SSU 2000e platform an excellent solution for next generation 4G/LTE and mobile backhaul networks.

Communications, Management and Security

The SSU 2000/SSU 2000e uses a single communication card, available in two different models: basic and RADIUS-Capable communication card. Coupled with Symmetricom's advanced

management software solutions, the communication module provides powerful fault, configuration, accounting/inventory, performance, security, and other optional management functions.

Both communications cards support the following management interfaces:

- Interactive Command Set (ICS), ASCII
- TL1
- SNMP (v2 or v3)

RADIUS, SSH, SFTP

The Remote Authentication Dial-In User Service (RADIUS) Capable communications card includes security features such as support for RADIUS authentication, Secure Shell (SSH) and Secure File Transfer Protocol (SFTP). This communications card was designed for environments where secure access to network elements is critical. Using SSH-encrypted client authentication and up to 32 characters for user ID and password access, it enables communication with a centralized

SSU 2000/SSU 2000e

server to authenticate remote users and authorize their access to the SSU 2000/SSU 2000e system. Four access levels (user, technician, supervisor or administrator) and automatic logout provide superior security access to the system, ideally suited to enterprise and international gateway deployments where secure remote access is required.

The RADIUS card also allows network administrators to schedule automatic firmware upgrades. System firmware in the master and expansion shelves can be scheduled for automatic updates without further human intervention. Using a secure FTP (SFTP) connection, this card can automatically download firmware from a remote server to upgrade the SSU 2000/SSU 2000e system (NTP and PTP cards must be individually updated using their management Ethernet port). Two system images can be stored on the card, giving the user the ability to update or revert to a standby image with a simple command.

TimeCraft

Available to support the SSU 2000/SSU 2000e, TimeCraft is an easy-to-use Graphical User Interface (GUI) management tool that reduces the complexity of using TL1 or CLI commands. Its intuitive GUI allows the operator to supervise and control a network element either remotely or locally through icons and simple point and click operations.

TimeCraft capabilities include support for remote firmware upgrades and provisioning to the port level, event-driven fault management, physical and logical configuration management, and performance and security management.

TimePictra®

The SSU 2000/SSU 2000e is fully supported by Symmetricom's TimePictra advanced Synchronization Management System. TimePictra provides full FCAPS capabilities (fault, configuration, accounting/inventory, performance and security) as well as an array of advanced management features, including the ability to monitor PTP clients.

With a multi-tier architecture (server, client, and database) TimePictra provides scalability and performance to meet growing network services and business needs. The secure web browser client provides easy access and eliminates the complexity of client installation and VPN access.

Symmetricom Global Services

Symmetricom provides synchronization services that assist customers with the planning, deployment and maintenance of synchronization infrastructure. Services are designed to help lower costs, streamline processes, ensure quality, and deliver the highest level of performance from your synchronization network.

The Platform Maintenance service bundles together Symmetricom's industry leading technical support along with all software maintenance. As part of Platform Maintenance, customer will receive all updates as well as all upgrades including all patches, point releases, maintenance releases and related documentation for your purchased version of software during the contract period.

SSU 2000 Access Using RADIUS Authentication

- 1 User requests access to SSU 2000 (using SSH protocol)
- 2 SSU 2000 requests user authentication from RADIUS server
- 3 RADIUS server authorizes user access
- 4 User communicates with SSU 2000 (using SSH protocol)

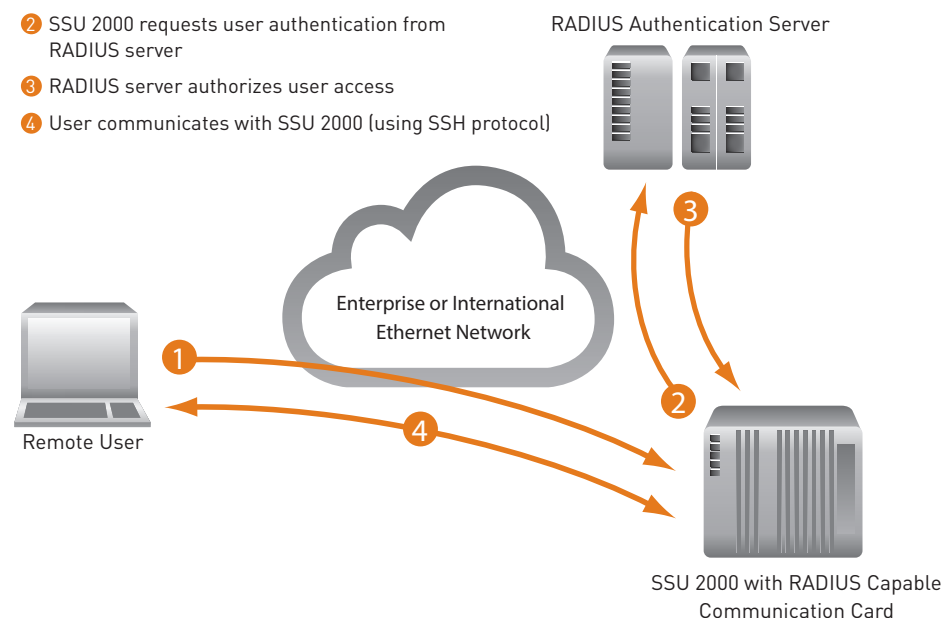

SSU 2000/SSU 2000e

Specifications

SHELF ARCHITECTURE, CAPACITY

SSU 2000 SYSTEM

- SSU 2000 Main Shelf, 12 slots: 2 clock, 1 communication, 9 for either input or output cards.
 - 27 total maximum input ports
 - 160 total maximum unprotected output ports
 - 80 total maximum protected output ports
- SDU 2000 Expansion Shelf, 16 slots: 2 buffer cards, 14 output cards
System supports 4 expansion shelves. The last expansion shelf in the chain can be located up to 200 feet away from the main shelf.
 - 280 total maximum unprotected output ports per shelf
 - 140 total maximum protected output ports per shelf
- SSU 2000 system total output capacity (main shelf plus 4 expansion shelves)
 - 1280 total maximum unprotected output ports
 - 640 total maximum protected output ports

SSU 2000e SYSTEM

- SSU 2000e Main Shelf: 12 slots: 2 clock, 1 communication, 3 input cards, 6 output cards.
Output slots are pre-wired for redundant pairs.
 - 9 total maximum input ports
 - 60 total maximum protected or unprotected output ports
- SDU 2000e Expansion Shelf, 12 slots: 2 buffer cards, 10 output cards
System supports 4 expansion shelves. Output slots are pre-wired for redundant operation. The last expansion shelf in the chain can be located up to 60 meters away from the main shelf.
 - 100 total maximum protected or unprotected output ports
- SSU 2000e system total output capacity (main shelf plus 4 expansion shelves)
 - 460 total maximum protected or unprotected output ports

INPUT

INPUT CARD TYPES

- T1 framed, 1/1.544/2.048/5/10 MHz sine or square wave, user settable
- E1 framed, 1/1.544/2.048/5/10 MHz sine or square wave, user settable
- Composite Clock
- 1.544 MHz or 6.312 MHz sine wave (Japan)
- Composite Clock (Japan)
- GNSS (GPS and GLONASS)
- GPS only

INPUT CAPABILITIES

- Embedded Sync Status Messaging (SSM)
 - Compliant with SSM specification per T1X1.3 TR33, ANSI T1.101-1999, ITU-T G.704, and Telcordia GR-253-CORE
- Integrated performance measurements (TIE, MTIE, TDEV, ERROR RATES) on all inputs
- Selection mode: Priority, SSM, Performance Mask
- Real time CPU: Intelligent software for real-time MTIE, TDEV and TIE performance monitoring.

GNSS/GPS CARDS

- Integrated single or dual (protected input) cards
- Compliant with Stratum 1 PRS (Primary Reference Source) per ANSI T1.101-1999, ITU-T G.811, Telcordia GR-2830/1244-CORE, and ETSI EN300 462-6.

PERFORMANCE MEASUREMENT

RESOLUTION

- Measurements are provided for each input versus each clock at a resolution of 1 ns

SAMPLING RATE

- 40 Hz for all frequency cards
- 1 Hz for GNSS/GPS cards
- 1 Hz averaging

CALCULATIONS

MTIE

- Meets or exceeds the latest ITU-T, ANSI and Telcordia standards with measurement intervals of 0.05 to 100,000 seconds. GNSS/GPS is 1 to 100,000 seconds

TDEV

- Exceeds the latest ITU-T, ANSI and Telcordia standards with measurement intervals of 0.1 to 10,000 seconds.

PHASE

- 1, 100, 1000, and 10,000 second phase averages and history are available.

FREQUENCY

- Frequency measurements can be viewed via user selectable calculation periods from 10 to 10,000 seconds.

CLOCK

CLOCK CARD TYPES

- Enhanced Rubidium, Stratum 2E Type II
- Enhanced Quartz, Stratum 3E Type III
- Enhanced Quartz, Type I for ITU-T standards

CLOCK PERFORMANCE

- Compliant with clock levels per ANSI T1.101-1999, ITU-T G.812, Telcordia GR-2380/1244-CORE and ETSI EN300 462-4

CONTROL

- DDS (Direct Digital Synthesis) technology for cost-effective calibration-free operation and precise frequency control

OUTPUT

OUTPUT CARD TYPES

All frequency cards have 20 output ports

- T1 (DS1)
- E1, port selectable 2.048 MHz/2.048 Mbps
- Composite Clock
- RS-422 (10 ports) and TTL (10 ports) provide output frequencies from 8 kHz to 4096 kHz in 8 kHz steps
- Sine Wave, 1.544MHz or 6.312 MHz (Japan)
- Composite Clock (Japan)

REDUNDANCY

- 1+1 output protection (both cards active)

NTP SERVER CARD

NETWORK PROTOCOL

- NTPv4 – RFC 5905 compliant
- Supports client and server modes in unicast and broadcast
- IPv4 (annex D)

TIME STAMPING

- Hardware Time Stamping
- Time Stamp Precision: <10 ns rms typical

TIME ACCURACY

- Tracking to GNSS (GPS or GLONASS): <250 ns when locked to GNSS source

INPUTS

- Stratum 1: from GNSS (GPS or GLONASS) input
- Stratum 2: full NTP client

TRAFFIC PORTS

- 2 Ethernet Small Form-factor Pluggable (SFP)
 - Optical: 1000Base-X
 - Electrical: 100/1000Base-T

SSU 2000/SSU 2000e

Specifications

TRANSACTION RATE

- Up to 1000 fully authenticated / 1500 unauthenticated transactions per second (TPS)

AUTHENTICATION

- MD5 (RFC 1321)

PROTECTION

- 1:1 protection (hot standby)

PTP GRANDMASTER CARD

NETWORK PROTOCOL

- IEEE 1588
 - Support for 1-step or 2-step clock
 - Unicast, layer 3 (with dynamic reservations)
- IPv4 (annex D)

PTP PROFILE

- ITU-T G.8265.1 Telecom
- Telecom-2008 v2

PTP CAPACITY

- Standard: up to 125 PTP clients per card at full rate of 128 messages/second
- License option: up to 400 PTP clients per card at full rate of 128 messages/second

TIME STAMPING

- Hardware Time Stamping
- Time Stamp Precision: <10 ns rms typical

TIME ACCURACY

- Tracking to GNSS (GPS or GLONASS): <250 ns when locked to GNSS source

TIME SCALE SUPPORT

- International Atomic Time (TAI), GPS card required
- Arbitrary Time Scale (ARB)

TRAFFIC PORT

- One Ethernet Small Form-factor Pluggable (SFP)
 - Optical: 1000Base-X
 - Electrical: 100/1000Base-T

VLAN SUPPORT

- 4 VLANs (IEEE 802.1Q)

PROTECTION

- 1:1 protection (hot standby)

SYNCHRONOUS ETHERNET OPTION

- 1000Base-X optical Ethernet output port
- Ethernet Synchronization Message Channel (ESMC) support
- ITU-T G.8261, G.8262, G.8264

COMMUNICATION & MANAGEMENT

MANAGEMENT

- The SSU 2000/SSU 2000e is a fully automated and software manageable system. Firmware upgrades can be remotely installed.

COMMUNICATIONS CARD TYPES

- Standard Communications Card
- RADIUS Capable Communications Card

COMMUNICATION PORTS

- RS-232 (EIA-232)
- Ethernet, 10Base-T

MANAGEMENT INTERFACE PROTOCOLS

- Simple fault, visual & contact closures
- TCP/IP, IPv4
- TL1
- Interactive Command Set (ICS), ASCII
- SNMPv2, SNMPv3 (optional)

RS-232 ports support ASCII and TL1, and Ethernet port supports all of the above. The Ethernet port supports four telnet sessions, two TL1 sessions, and five SNMP messages

EVENT LOG

- Stores up to 1000 events from any system faults, user interventions, and system actions. Events are time & date stamped to less than 1 msec

SECURITY

- Standard Communication Card
 - User ID length: up to 20
 - User password length: up to 12
 - User access levels: 4
- RADIUS Capable Communication Card
 - Secure Shell (SSH)
 - Secure FTP (for system software updates)
 - User ID length: up to 32
 - User password length: up to 32
 - User access levels: 4

MANAGEMENT SOFTWARE

Available management programs (see separate datasheets)

- TimeCraft Windows GUI-based local management terminal
- TimePictra Synchronization Management System

ENVIRONMENTAL

POWER

- Dual -38 to -75 VDC
- SSU 2000: Less than 120 watts power consumption per shelf
- SSU 2000e: Less than 100 watts power consumption per shelf

SIZE (HxWxD)

- SSU 2000: 10.5" x 17" x 11.5" (26.7 cm x 43.2 cm x 293.2 cm)
 - SSU 2000e: 19.6" x 17" x 9" (50 cm x 43.2 cm x 22.9 cm)
- Widths do not including mounting ears

WEIGHT (provisioned)

- SSU 2000: approx. 27 lbs (12.3 kg) main unit
- SSU 2000e: approx. 27 lbs (12.3 kg) main unit

TEMPERATURE

- Operating temperature: 0°C to 50°C
- Storage temperature: -20°C to 75°C
- Relative humidity: 80% non-condensing

EMC

- Radiated emissions per Class B requirements
- EN 300 386-2
- GR-1089-CORE

RoHS

- 5 of 6